

IP NDAA S-SIGHT SERIES

Provision-ISR S-SIGHT series provides you with all you need for a simple installation. S-Sight cameras guarantee superior image quality, improved night performance and make an outstanding value-for-money solution.



DMA-350IPSN-28-V4

10M IR 5MP DDA ANALYTICS FIXED LENS MINI DOME ANTI-VANDAL CAMERA WITH BUILT-IN CHECK POINT PROTECTION AND DUAL SYSTEM TECHNOLOGY

The DMA-350IPSN-28-V4 has a 2.8mm fixed lens and a protective dome. With its 11cm diameter, this 5MP mini-dome camera is designed for short-distance surveillance (up to 10m) in indoor scenarios. The vandal-proof IK10 protection makes it extremely hard to sabotage. Fitted with the new "Dual System" technology, the camera can deal with internal anomalies independently, making it more redundant to software-based issues. The camera offers outstanding DDA Analytics (Detect, Distinguish, Alert), which can perform human and vehicle recognition. With various detection rules and triggers, the DMA-350IPSN-28-V4 is here to end false alarms and, with the Check Point protection, ensures that your devices are cyber-protected round the clock.

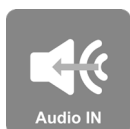

MAIN FEATURES

- 5MP
- NDAA EYE-SIGHT
- 2880x1620 Resolution
- Wide field of view 108°
- 3D-DNR
- IK10
- Mini Dome
- DDA Analytics
- Audio in + Built-in microphone

ANALYTICS

- General Analytics: Camera Tampering
- AI (Object Recognition): DDA Sterile Area, DDA Line Crossing



SPECIFICATIONS

Image Sensor	1/2.7" CMOS (16:9)
Effective Pixels	2880x1620
Electronic Shutter	1/2s ~ 1/100000s
Frame Rate	1-25/30FPS
Day & Night	ICR
Min. Illumination	Day: 0.1lux / Night: 0.005lux (@F1.6, AGC on) 0lux with IR on
Audio compression	G.711A/G.711U
Communication	One-Way Audio
Image Settings	AWB, AGC Adjustable, Exposure Mode (Auto) Sharpness, Saturation, Brightness & Contrast Adjustable
Image Enhancement	True WDR (120dB), BLC, HLC, ROI
Noise Reduction	3D-DNR
Image Orientation	Mirror/Flip
Privacy Zone	Yes
Motion Detection	Yes
Analytics	General Analytics: Camera Tampering AI (Object Recognition): DDA Sterile Area, DDA Line Crossing
DRI Distance	Detect 59.67m(195.76ft) Recognize 11.93m(39.14ft) Identify 5.97m(19.58ft)
Video Compression	H.265+/H.264+/H.265/H.264/MJPEG*
Resolution	5MP (2880x1620) / 4MP (2560x1440) / 3MP (2304x1296) / 2MP (1920x1080) / 1MP (1280x720) / D1 (704x576) / QVGA (480x240) / CIF (352x288)
Multi-Stream	Master Stream: 5MP (2880x1620) (1~20fps) / 4MP (2560x1440) / 3MP (2304x1296) / 2MP (1920x1080) / 1MP (1280x720) (1~30fps) Substream: 1MP/QVGA/D1/CIF Third Stream: D1/CIF (1~30fps)
Bit rate	64Kbps ~ 4Mbps@H.265 / 64Kbps ~ 6Mbps@H.264
Encode Mode	VBR/CBR
Image Quality	Five levels under VBR; Free adjustment under CBR
IR Distance	10m (2 High-Power IR LED)
Lens (Field of View)	2.8mm (108°)

*Substream only

SPECIFICATIONS

Iris	Fixed Iris
Lens Mount	M12 mount
Protection Rate	Vandal Proof: IK10
Bracket	3-Axis Gimbal
Dimensions	Φ110.4mm×62mm
Weight (gross)	410g
Network	RJ45 (+PoE)
Power	DC Socket
Analog Video Output	No
Audio Connectivity	Built-in Microphone + Audio input
SD Card	Event/Schedule based Main/Substream recording (Up to 256Gb)
Hard Reset Button	Yes
Alarm	No
Remote Monitoring	IE Browsing, VMS Software, Provision Cam2 Mobile App
User Access	Supports simultaneous monitoring of up to 3 users with multi-stream real-time transmission
Network Protocol	IPv4, IPv6, TCP, UDP, DHCP, NTP, DDNS, 802.1X, RTSP, Multicast, UPnP, Email, FTP, HTTPS, QoS, P2P
ONVIF	Yes
Ethernet	100Mbps
PoE	Yes
Power Supply	DC12V/~300mA / PoE/~5W
Work Environment	-30°C~50°C, 10%~90% Humidity
Junction Box	PR-WB-A - PR-B10BJB

DIMENSIONS

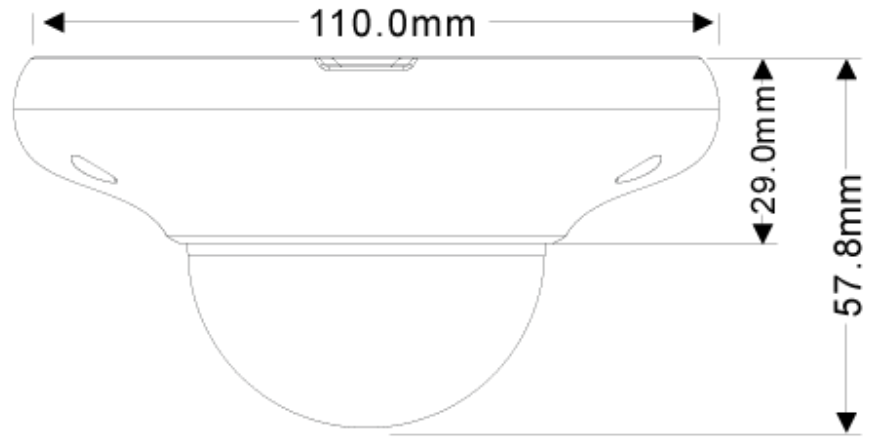

ACCESSORIES

For DMA

